



XTAR®

D30 6000

6000lm Diving Flashlight

100m underwater photography light

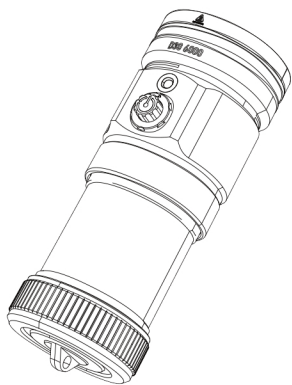

V6

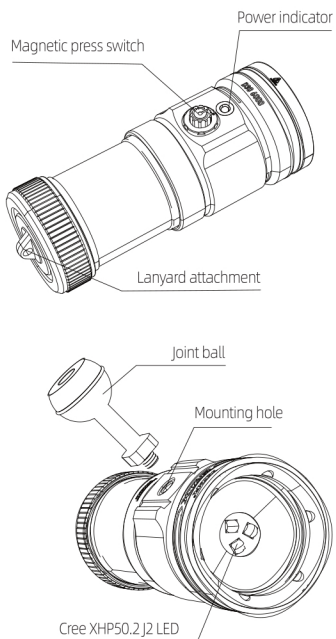

Introduction

D30 6000 features super bright 6000lm, run time up to 45minutes, CRI>90. with joint ball, users can mount it on underwater sport camera or diving gear, and catch the stunning moments of 100m underwater scenes.

Parameters

ANSI	Flood
	High
Luminance	6000lm
Run time	45minutes
CRI	>90
Beam angle	140°
Beam Throw	89m
Impact Resistant	1.5m
Waterproof	IPX8, Underwater 100m
Size	Φ62mm(head) × 157mm(length)

Note: above data is derived from XTAR Lab., and tested base on 4 protected 18650 3600mAh Li-ion batteries.

Operation

■ Insert batteries

Open the tail cap, and insert batteries properly with "+" towards the head.

■ Lock and unlock

A. Lock: in the unlocked state, anticlockwise rotate switch 45° to get it locked.

B. Unlock: in the locked state, clockwise rotate switch 45° to get it unlocked.

■ Power indicator

Battery power	Power indicator	Solutions
>20% (sufficient)	Green	Under good condition
20%-5% (nearly low)	Red	Please charge timely
<5% (low)	Red flashing	Please charge timely or it will power off 10min later

■ Use accessories

A lanyard can be attached to the tail of light; also a mounting hole for handle or joint ball is placed on the housing.

■ Tips

1. Please make sure that batteries "+" are towards the head.
2. Since the light will consume power after power off, please remove batteries when not planning to use the light for some time.
3. Do not wipe batteries with any corrosive material.
4. Light fails to start.

Possible causes	Solutions
Battery is out or not compatible	Change batteries
Batteries improperly placed inside	Make sure that batteries "+" are towards the head
Poor contact	Clean the contact surface of batteries with alcohol Tighten the head or tail cap

5. For more information, please visit www.xtar.cc

After-sales

Please provide warranty number to our dealer to get after-sales service.

- 15 days free replacement.
- 24 months free repair. If problem developed is beyond 24 months, we will offer free repair service but charge for parts used.
- Lifetime technical support.

Note:

1. Damage caused by misuse or intentional abuse is not covered by the warranty.
2. Warranty number (9-13 digits) can be found on the package or product.

Global After-sales Email: service@xtar.cc

Anti-fake inquiry

1. Scratch the anti-counterfeiting label on the package to get 18-digit number.
2. Input the number into the query page on www.xtar.cc (Contact Us - Anti-fake).



Warning: Do not radiate the light directly towards the eyes, serious injury or blindness could occur by misuse.

Company info: Shenzhen XTAR Electronics Co., Ltd
 Address: 5th Floor, No.77 Xinhe Rd, Shangmugu, Pinghu Area, Longgang District, Shenzhen, Guangdong, China
 Zip Code: 518111
 Website: www.xtar.cc Email: info@xtar.cc
 Tel / Fax: +86-755-25507076

Made in China